

## Connected Home Window Contact

SCH020ZB



### **Detects open/close status of doors and windows.**

- Easy to install practically anywhere: doors, windows, drawers, cupboards, jewelry boxes and more
- No power connection required; battery operation gives you the flexibility to install the sensor nearly anywhere
- Monitoring records notify you when something opens
- Communicates with Connected Home Hub via Zigbee network

## Use

You can install Connected Home Window Contact (the sensor) on door or window to detect its open/close status.

## Mechanical design

The sensor consists of the following parts:

- Front housing (sensor)
- Back housing (sensor)
- Mounting plate (sensor)
- Magnet
- Front housing (magnet)
- Mounting plate (magnet)

## Sensor layout

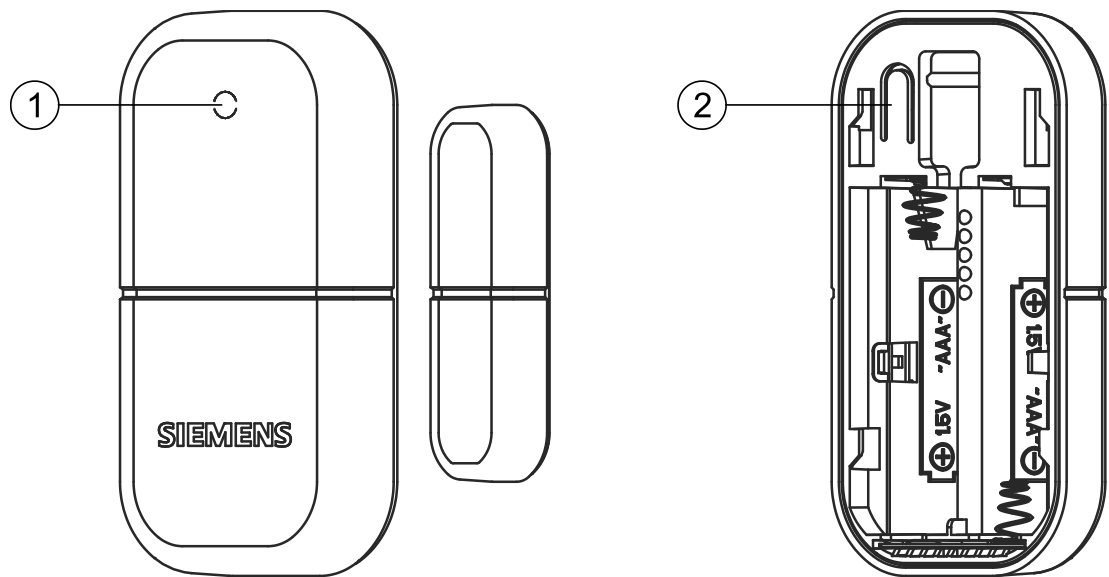

No.	Description
1	LED indicator
2	Button for user operation: <ul style="list-style-type: none"><li>• Press it shortly to check sensor status.</li><li>• Press and hold it down for 3 s to join Zigbee network (initiated from the mobile application).</li><li>• Press and hold it down for 10 s to perform factory reset.</li><li>• See LED indication [ ▶ 3] for more information.</li></ul>

Sensor state	Checking method <sup>1)</sup>	LED state
Sensor not added to the hub	Press the operation button shortly or reinstall the batteries	Solid amber for 8 s then turns off
Low battery		Flashes red fast for 8 s then turns off
Successful connection	Press the operation button shortly or after the connection is successfully established	Solid green for 8 s then turns off
Zigbee network failure <sup>2)3)</sup>	Press the operation button shortly	Flashes red slowly for 16 s (1 s on, 1 s off, 1 s on)
Firmware upgrade in process		Flashes amber for 8 s then turns off
Door/window opening/closing detected	No operation needed	No LED indication by default, but can be enabled in the mobile application. If enabled, when the sensor detects door/window opening/closing, the LED turns to green for 1 s, then turns off.

Activity	Operation on the sensor	LED state
Join Zigbee network (initiated from the mobile application, 2-minute timeout)	Press and hold down the operation button for 3 s	Flashes green fast
Perform factory reset	Press and hold down the operation button for 10 s	Flashes red and green alternately and fast, and then turns off. After 1 to 3 seconds, the LED turns to solid amber for 8 seconds and then turns off.
Locate sensor (initiated from the mobile application when Zigbee network connection is normal)	No operation needed	Flashes green slowly (1 s on, 1 s off, 1 s on) until location is complete, then turns off

1. If the checking method is the same, priority of LED state indication (high to low) is: low battery > Zigbee network status > firmware upgrade.  
For example, if there is a Zigbee network failure when battery level is low, the LED flashes red fast rather than slowly.
2. Check if the hub is powered on and try to reduce distance between the sensor and the hub.
3. Try network reconnection.
  - Remove the sensor from the mobile application, perform factory reset and then rejoin the Zigbee network.

## Operation and settings

You can do the following on the sensor:

- Add the sensor to the hub after the mobile application initiates the joining process.
- Reset the sensor to factory settings.
- Indicate door/window opening or closing status.

See LED indication [ ▶ 3] for information on the above operations. Other operations, such as assigning the sensor to a room and viewing monitoring records on door/window opening or closing, are only available in the mobile application.

## Type summary

Type	Stock number	Description
SCH020ZB	S55772-T116	Connected Home Window Contact

## Ordering

When ordering, indicate product number, stock number and description.

## Inbox items

Items	Quantity
Sensor and magnet	1
Battery (LR03 - AAA)	2
Mounting instructions	1

## Equipment combinations

Product number	Stock number	Description
GTW100ZB	S55772-T109	Connected Home Hub

## Product documentation

Title	Document ID
Mounting instructions	A6V13959840
CE declaration	A5W00705027A
UKCA declaration	A5W00705028A
Product environmental declaration	A5W00670144A

Related documents such as the environmental declarations, declarations of conformity, etc., can be downloaded from the following Internet address:

[www.siemens.com/bt/download](http://www.siemens.com/bt/download)

## Safety

### ⚠ CAUTION



#### National safety regulations

Failure to comply with national safety regulations may result in personal injury and property damage.

- Observe national provisions and comply with the appropriate safety regulations.



#### For indoor use only

The sensor is for indoor use only. Do not place it outdoors.

## Mounting

- Recommended gap between the sensor contacts: less than 22 mm.
- Avoid direct solar radiation.
- Adhere to allowed ambient conditions.

## Installation

The mounting plate of the sensor can be installed on door or window. The sensor is for indoor use only.

### ⚠ WARNING



#### Risk of explosion

Personal injury and property damage

- Install the battery at the correct polarity (+/-) using the illustration in the battery compartment.
- Install only the correct battery types according to the indication in the battery compartment.
- In case of a leakage, avoid contact with skin, eyes and mucous membranes.
- Remove leaking battery from the battery compartment with a cloth.

Observe the following:

- The batteries must be undamaged.
- Do not mix new and used batteries when installing/replacing batteries.
- The batteries are for normal use under normal ambient room temperature.
- Remove the back cover to install/replace batteries. See the [Mounting instructions](#) for details.
- Remove the batteries before disposing of the sensor.
- Dispose of the exhausted batteries in compliance with environmental requirements.

## Maintenance

The sensor is designed for maintenance-free operation.

## Open Source Software (OSS)

### Software license overview

The device uses Open Source Software (OSS). All Open Source Software components used in the product (including copyrights and licensing agreement) are available at <http://siemens.com/bt/download>.

OSS document ID	Device
A6V14538718	SCH020ZB

## Disposal



This symbol or any other national label indicate that the product, its packaging, and, where applicable, any batteries may not be disposed of as domestic waste. Delete all personal data and dispose of the item(s) at separate collection and recycling facilities in accordance with local and national legislation.  
For additional details, refer to [Siemens information on disposal](#).

## Warranty

Technical data on specific applications are valid only together with Siemens products listed under "Equipment combinations". Siemens rejects any and all warranties in the event that third-party products are used.

<b>Power supply</b>	
Operating voltage	DC 3 V (2 x AAA Alkaline batteries)
Battery life	Up to 2 years

<b>Radio parameters</b>	
Frequency band	2.4...2.4835 GHz
Maximum radio-frequency power	< 10 dBm (antenna gain is 0...2, depending on models)
Communication standard	Based on Zigbee
MAC protocol	IEEE 802.15.4
Communication range*	30 m (indoor)
Zigbee channels	11...26
Pairing method with GTW100ZB	Global Link Key

\* The range depends largely on building structure and indoor environment.

<b>Ambient conditions and protection classification</b>	
Degree of pollution	2
Overvoltage category	I
Protection against electrical shock as per EN 60730-1	Protection class III
Degree of protection of housing as per EN 60529	IP30
<b>Climatic ambient conditions</b>	
Operation (in dry locations having no temperature or humidity control)	Temperature: 0...50 °C Ambient humidity: 5...95 % r.h. (Non condensing)
Transport and storage (in packaging)	Temperature: -25...+70 °C Ambient humidity: 5...95 % r.h. (Non condensing)
Operation altitude	Max. 3,000 m above sea level

Standards, directives and approvals	
Electromagnetic compatibility	For residential and commercial environments
EU conformity (CE)	See EU declaration of conformity A5W00705027A*
UK conformity (UKCA)	See UK declaration of conformity A5W00705028A*
Environmental compatibility	The product environmental declaration A5W00670144A* contains data on environmentally compatible product design and assessments (RoHS compliance, materials composition, packaging, environmental benefit, disposal).

\* The documents can be downloaded from [www.siemens.com/bt/download](http://www.siemens.com/bt/download).

General	
Dimensions	See "Dimensions [▶ 8]"
Color	RAL9016
Sensor	Digital magnet sensor
Sensitive distance	≤ 22 mm
Firmware upgrade	Via the mobile application
Weight (net)	55 g
Weight (with box, user document and accessory)	94.5 g

## Dimensions

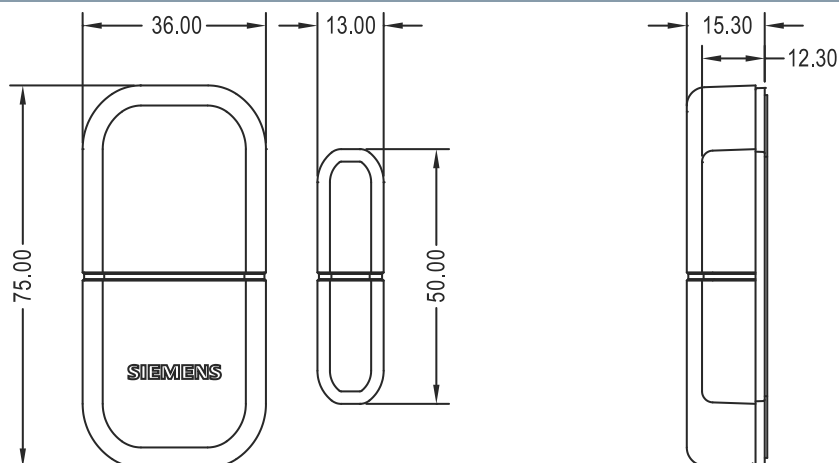



Issued by  
Siemens Switzerland Ltd  
Smart Infrastructure  
Global Headquarters  
Theilerstrasse 1a  
CH-6300 Zug  
+41 58 724 2424  
[www.siemens.com/buildingtechnologies](http://www.siemens.com/buildingtechnologies)

© Siemens 2024  
Technical specifications and availability subject to change without notice.

---

Document ID    A6V13959555\_en--\_c  
Edition        2025-01-23